

GothiX - 10r
 Arrangement Scale 1:5
 Dwg 1 of 7 300613

LOA = 1600 mm
 LWL = 1225 mm
 BOA = 180 mm
 BWL = 173 mm
 Draught = 690 mm

Disp = 5.65kg

SA = 1.019326 m2.

Base Line

100mm

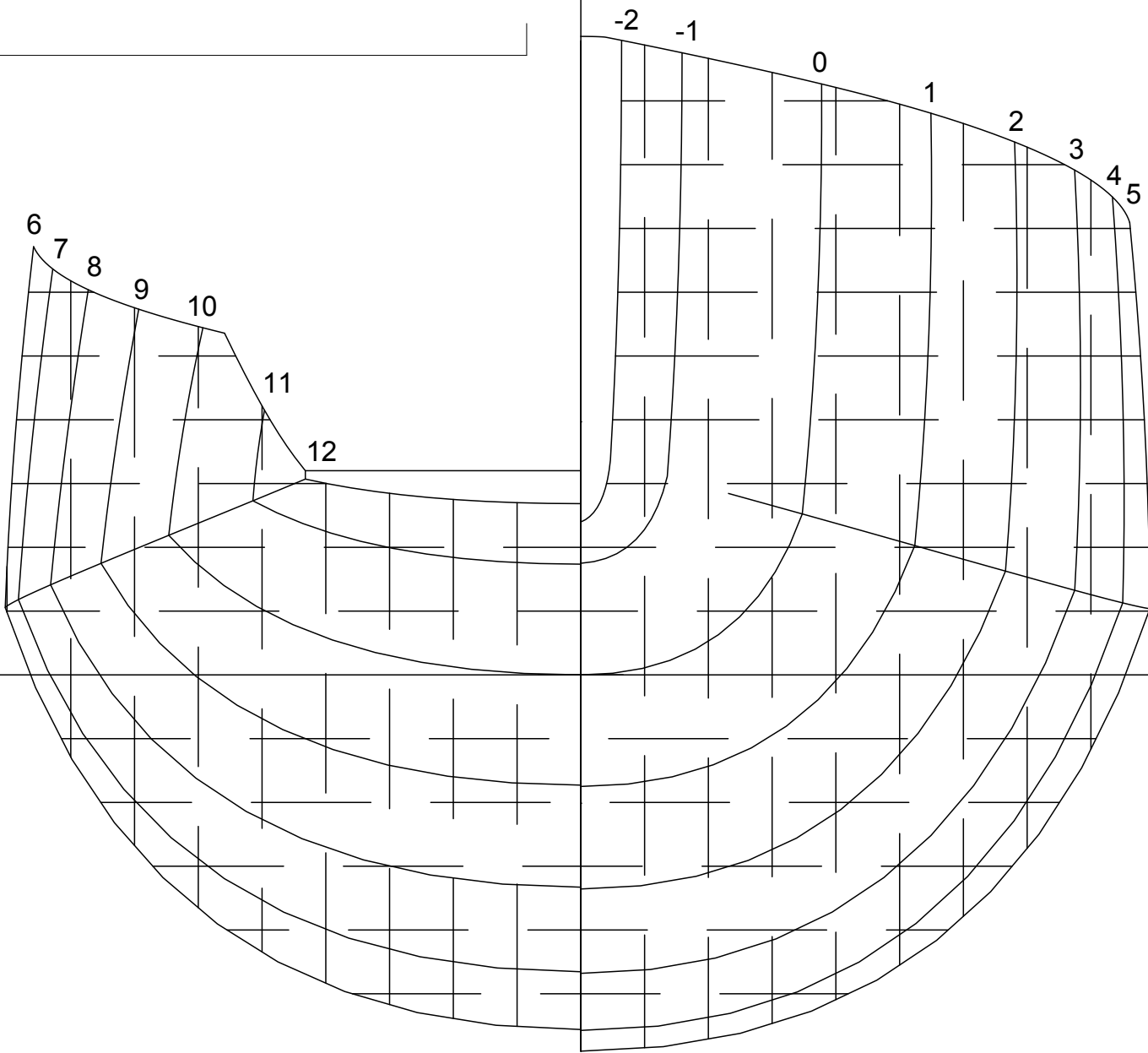

DWL

DWL

GothiX - 10r
Sections Scale 1:1
Dwg 2 of 7 290613

Base Line

100mm

DWL

DWL

GothiX - 10r

Bow Sections Scale 1:1

Dwg 3 of 7 290613

© Frank Russell 2013

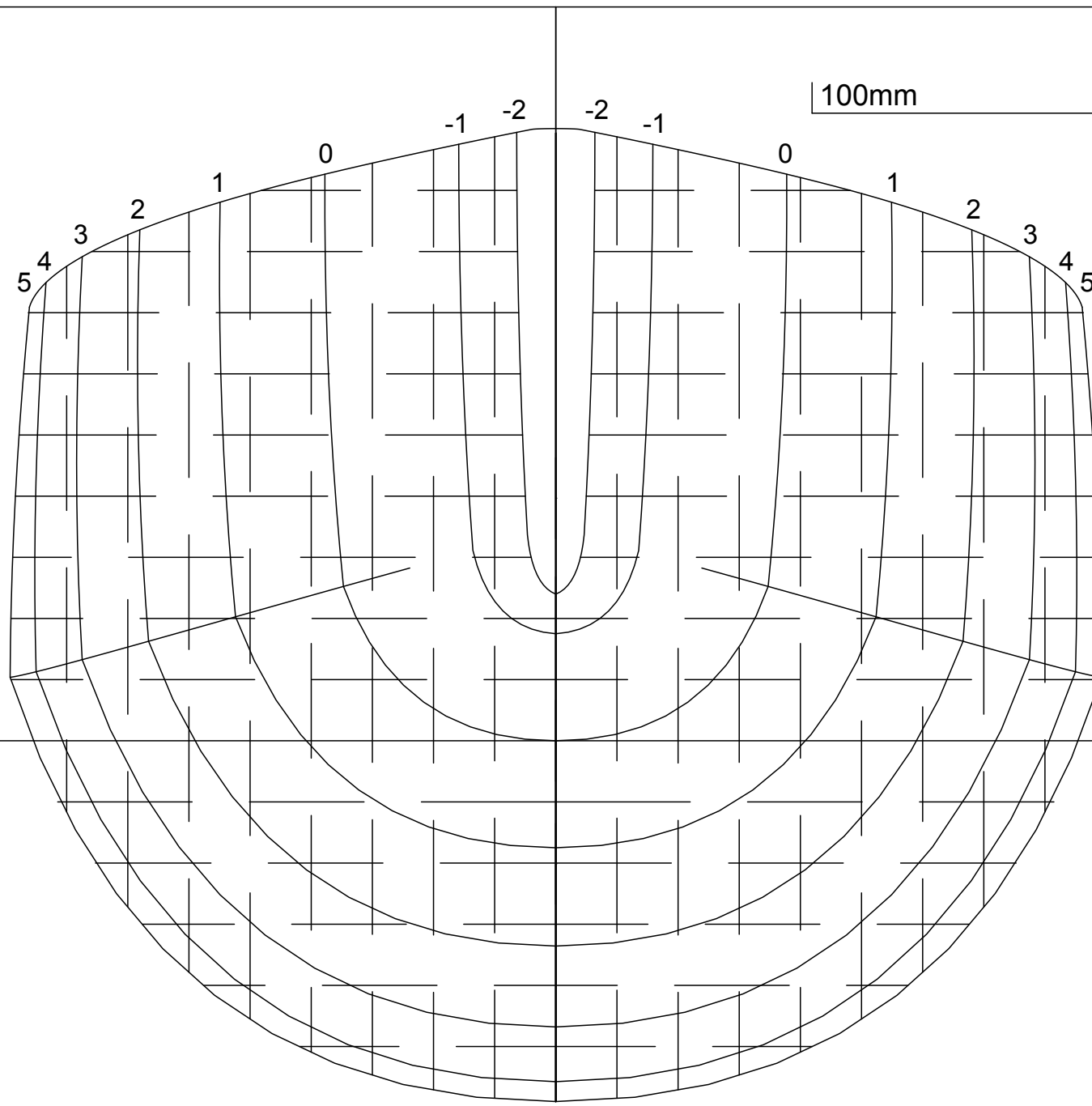

Base Line

100mm

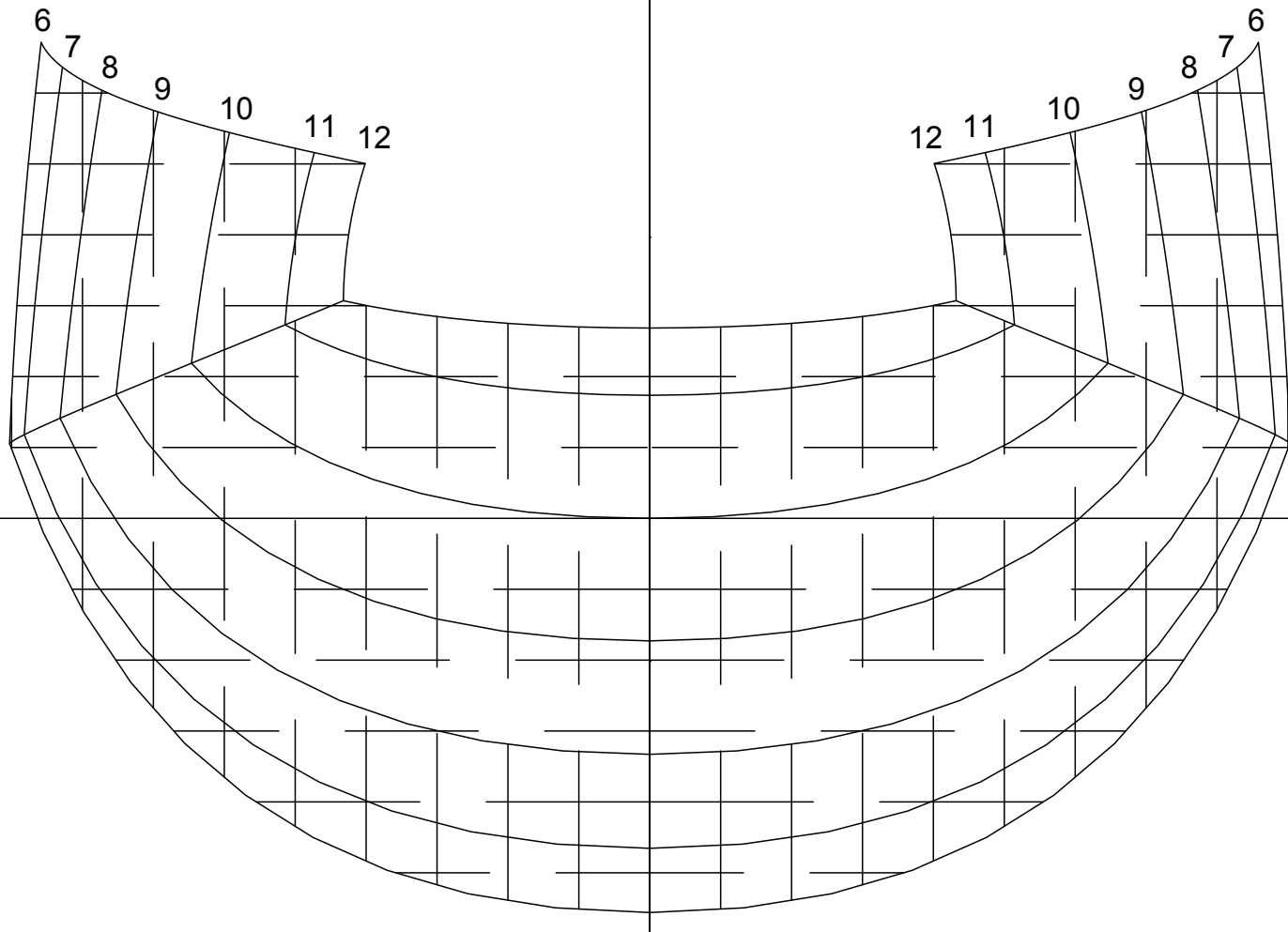

DWL

DWL

GothiX - 10r

Stern Sections Scale 1:1

Dwg 4 of 7 290613

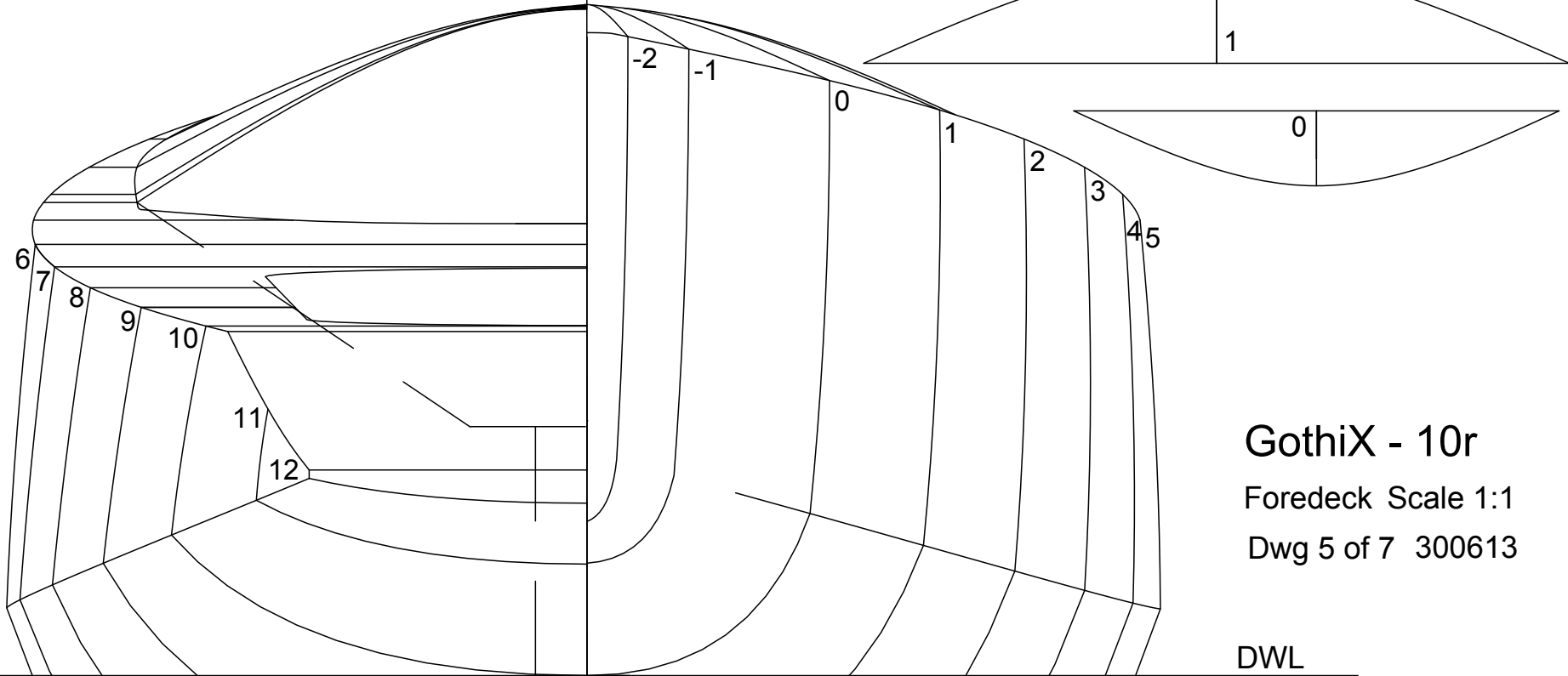
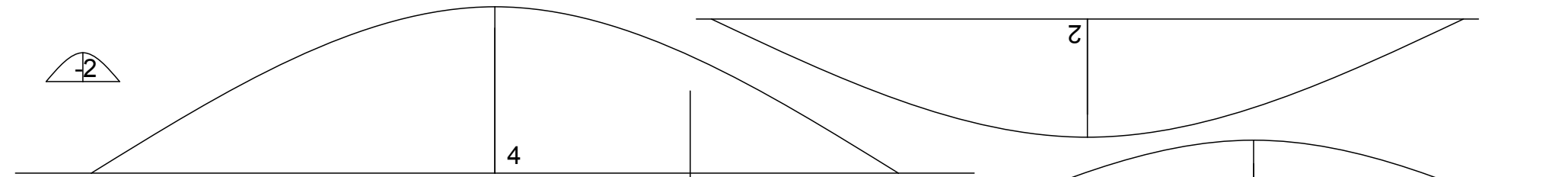
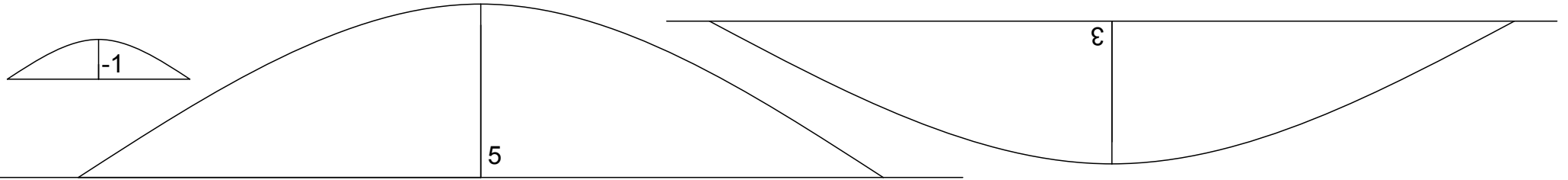

GothiX - 10r
 Foredeck Scale 1:1
 Dwg 5 of 7 300613

100mm

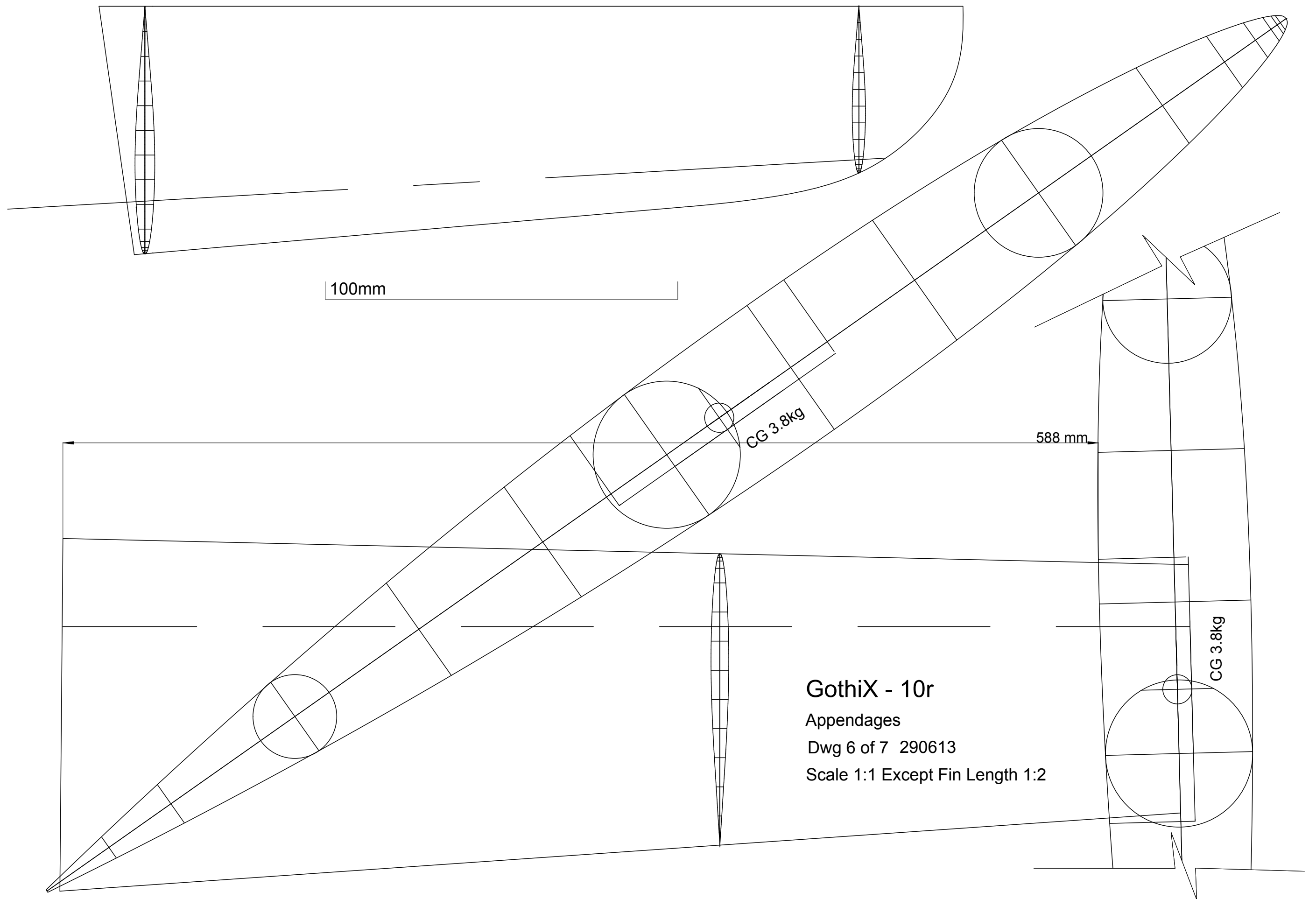

GothiX - 10r

Appendages

Dwg 6 of 7 290613

Scale 1:1 Except Fin Length 1:2

GothiX - 10r

Sail Plans Scale 1:10

Dwg 7 of 7 290613

Sail 1 Mainsail = 621815 mm²

Sail 2 Jib = 370817 mm²

Spar1 Mast = 26694 mm²

Total = 1019326 mm²

S = 1.019326

Rating = $1.225 \times 1.019326 \times 8 = 9.99$

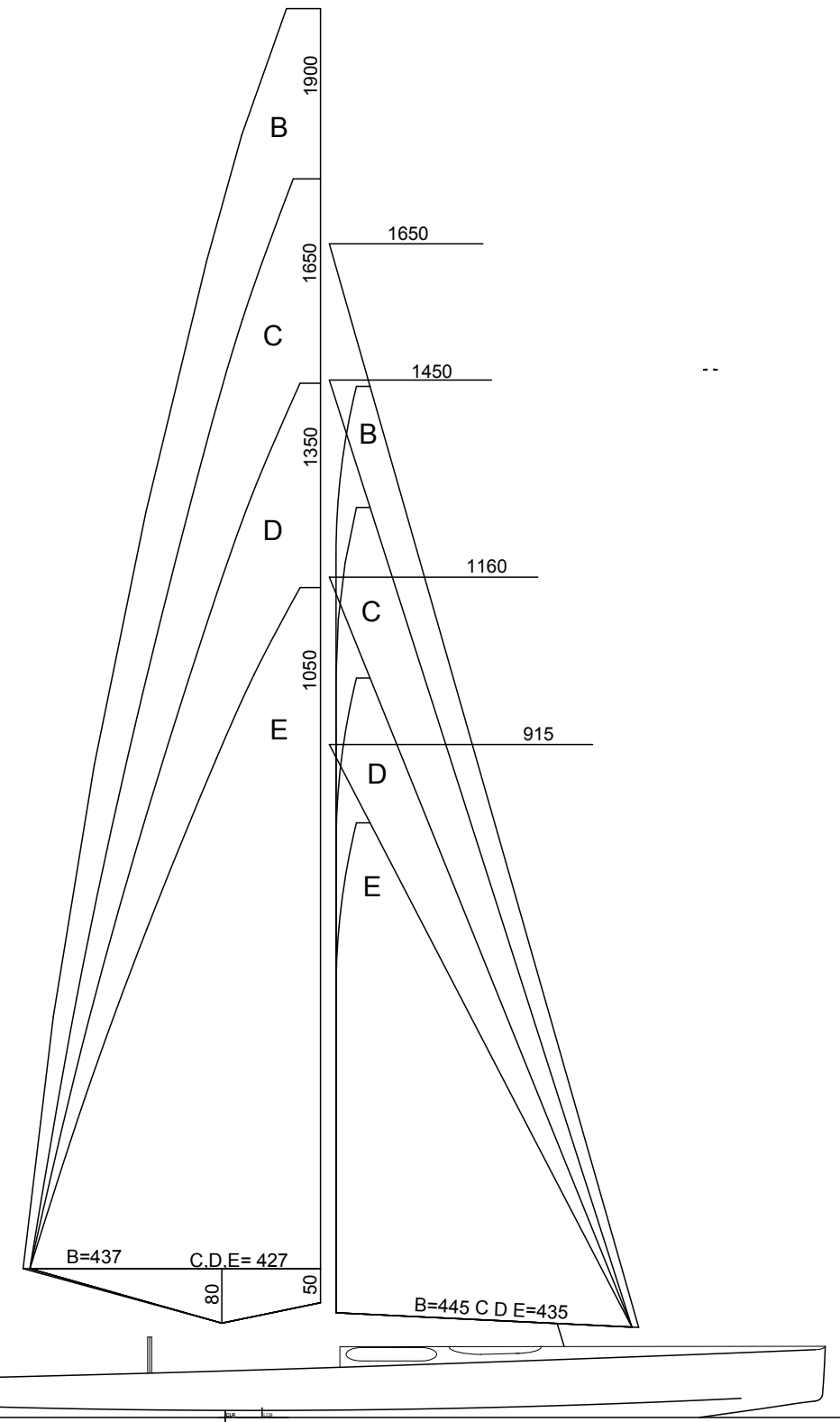
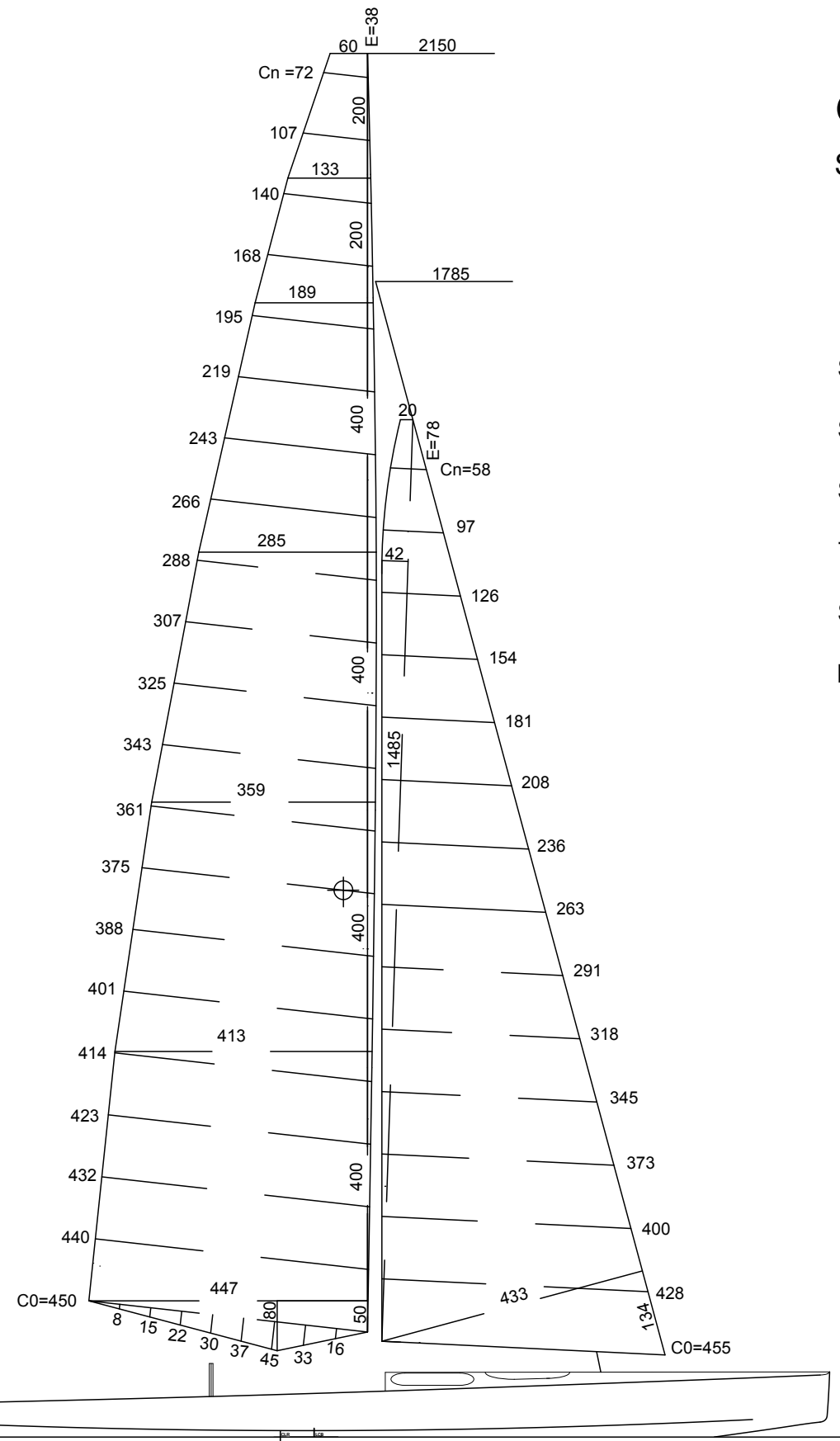

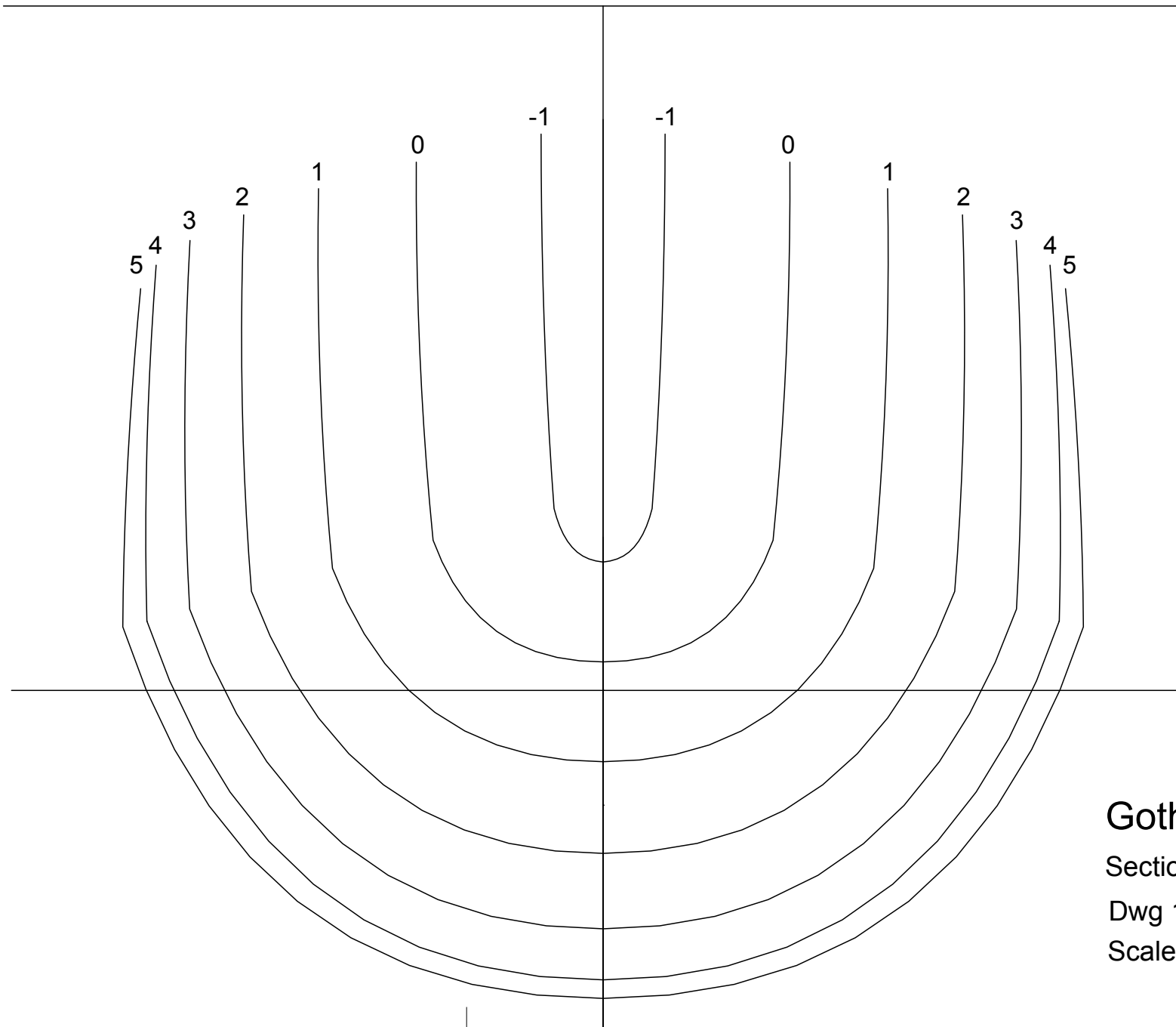

GothiX - 10r

Sections Less 5mm

Dwg 1 of 2 050813

Scale 1:1

100mm

© Frank Russell 2013

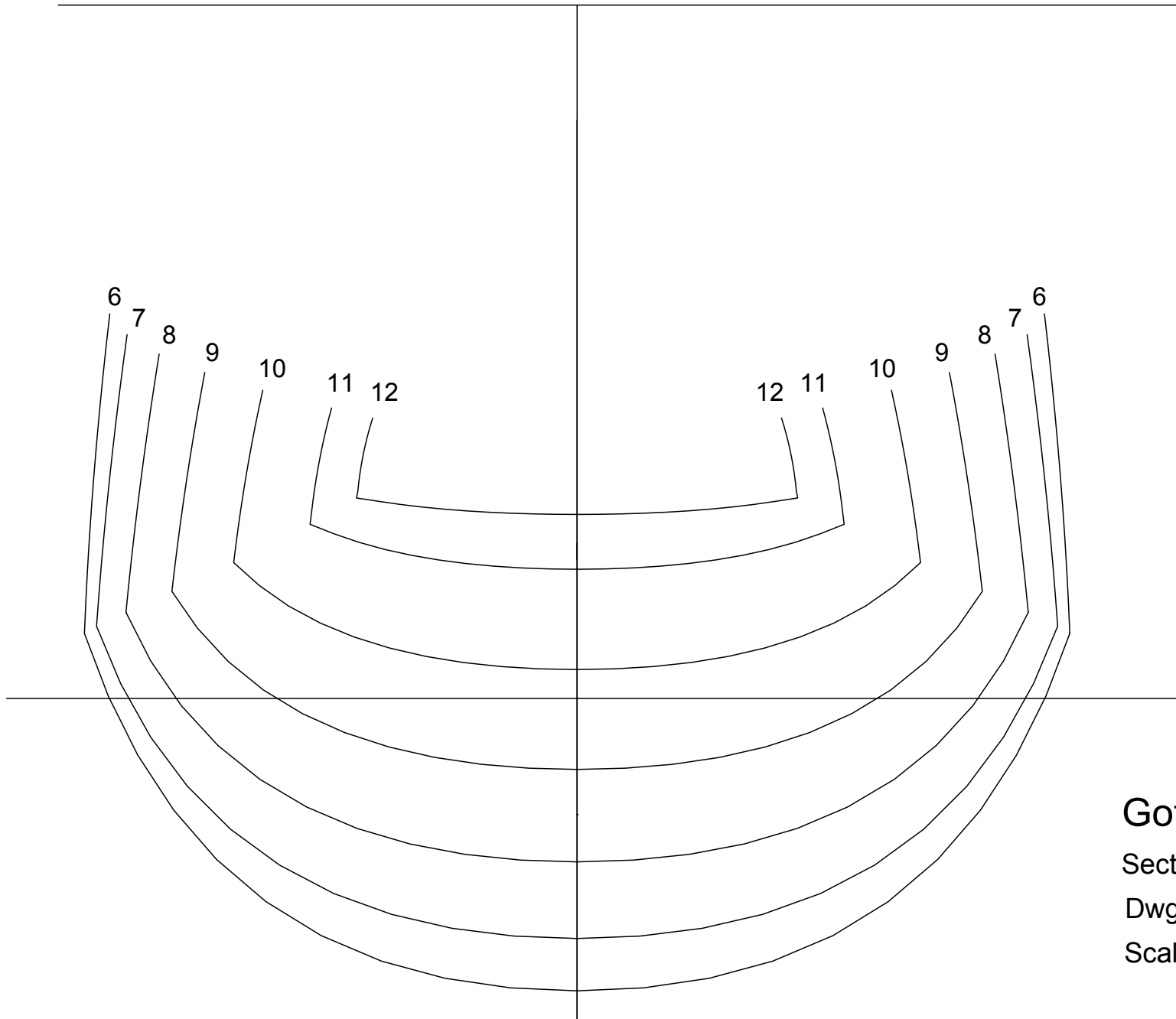

GothiX - 10r
Sections Less 5mm
Dwg 2 of 2 050813
Scale 1:1

100mm